

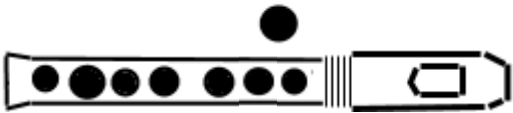

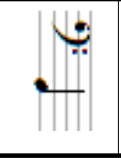

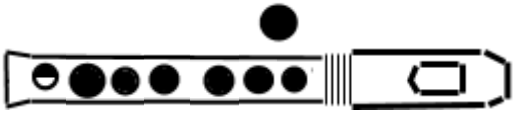

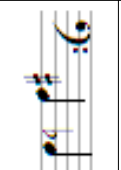



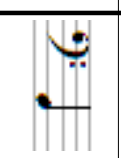

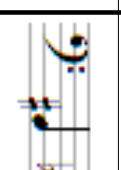
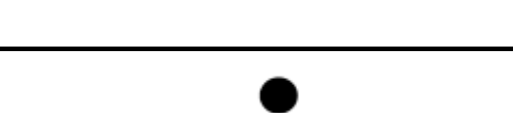
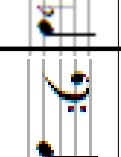

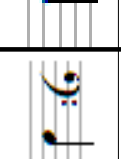

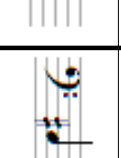
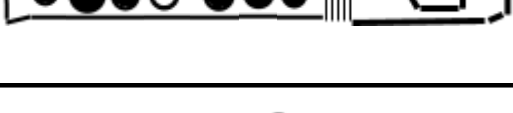
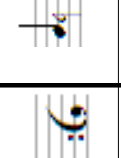

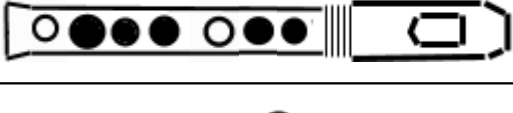

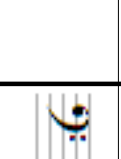

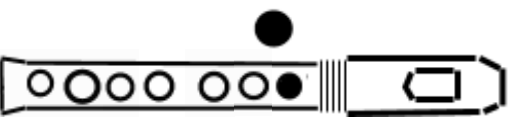

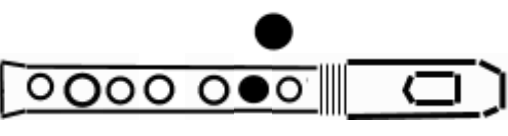
Blockis Blockflötengriffe

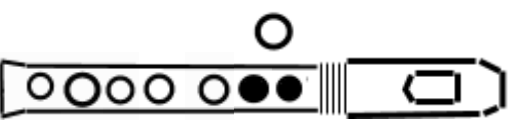

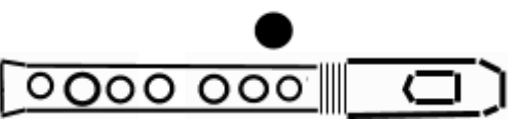
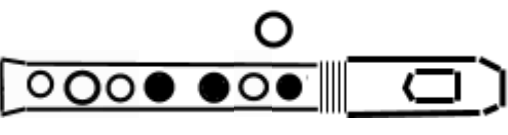
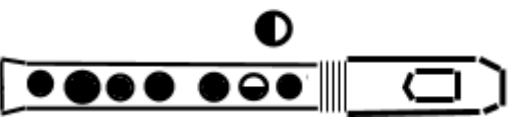
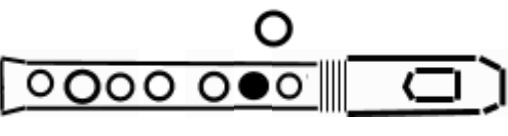

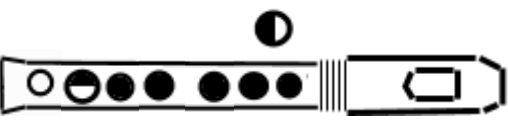

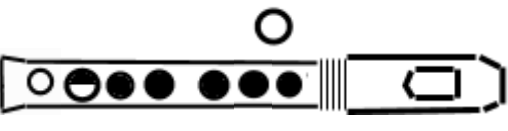



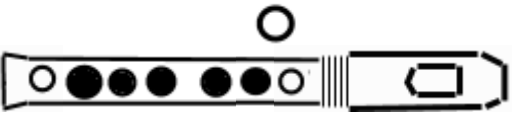
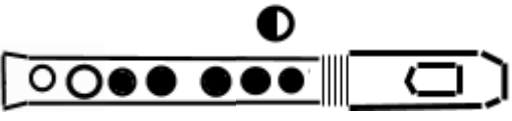

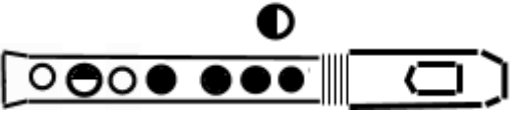

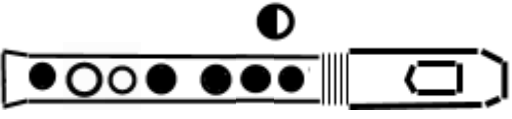
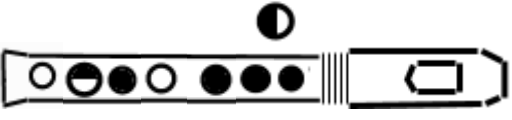
-- Ganassi Griffe -- Bass in G

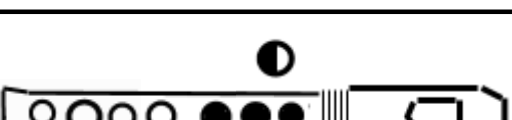
| | | | |
|-----------------------------|---|---|-----------------------------|
| G 1. Oktave |  |  | G 1. Oktave |
| Gis/As 1. Oktave |  |  | Gis/As 1. Oktave |
| A 1. Oktave |  |  | A 1. Oktave |
| Ais/B 1. Oktave |  |  | Ais/B 1. Oktave |
| H 1. Oktave |  |  | H 1. Oktave |
| C 1. Oktave |  |  | C 1. Oktave |
| Cis/Des 1. Oktave |  |  | Cis/Des 1. Oktave |
| D 1. Oktave |  |  | D 1. Oktave |
| Dis/Es 1. Oktave |  |  | Dis/Es 1. Oktave |
| |  | | |
| E 1. Oktave |  |  | E 1. Oktave |

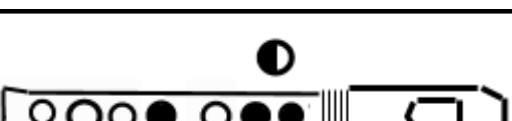

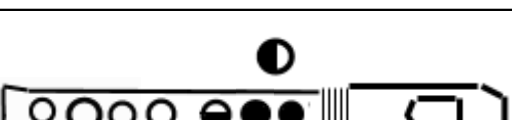
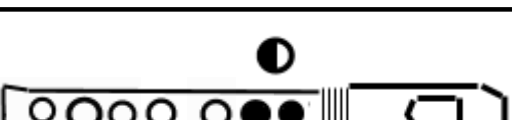

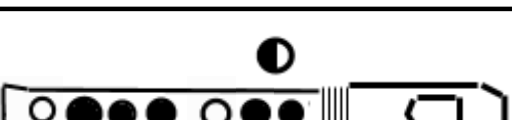

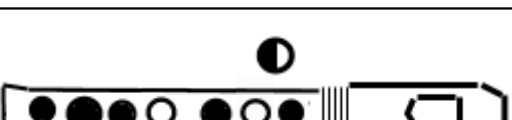
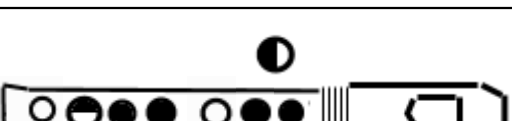
-- Ganassi Griffe -- Bass in G

| | | | |
|---|---|-------------------------------------|---|
| <p>F 1. Oktave</p> |  | <p>F</p> |  |
| <p>Fis/Ges 1. Oktave</p> |  | <p>Fis</p> |  |
| <p>G 2. Oktave</p> |  | <p>G</p> |  |
| <p>Gis/As 2. Oktave</p> |  | <p>Gis</p> |  |
| |  | <p>Bindung mit G + A</p> | |
| |  | <p>Bindung mit F</p> | |
|  | | | |
| <p>A 2. Oktave</p> |  | <p>A</p> |  |
| <p>Ais/B 2. Oktave</p> |  | <p>Ais</p> |  |
| |  | | |

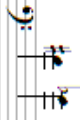
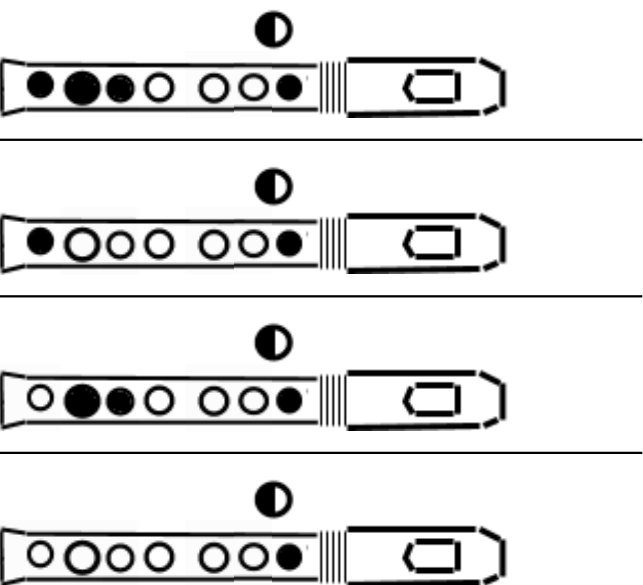
-- Ganassi Griffe -- Bass in G

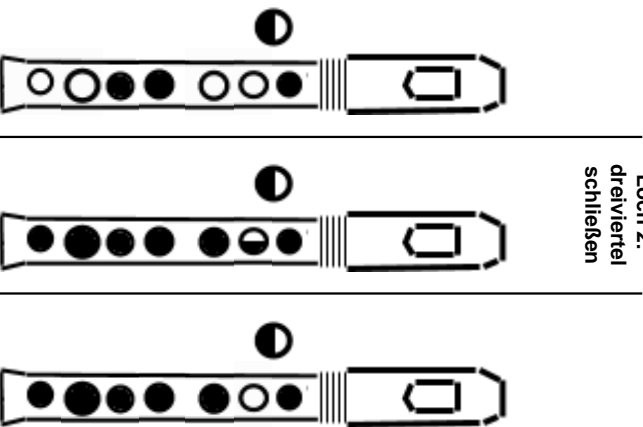
| | | | |
|-----------------------------|--|---|---|
| | |  | |
| H 2. Oktave | |  |  |
| C 2. Oktave | |  |  |
| | |  | |
| Cis/Des 2. Oktave | |  |  |
| D 2. Oktave | |  |  |
| Dis/Es 2. Oktave | |  |  |
| | |  | |
| E 2. Oktave | |  |  |
| F 2. Oktave | |  |  |
| | |  | |
| | |  | |

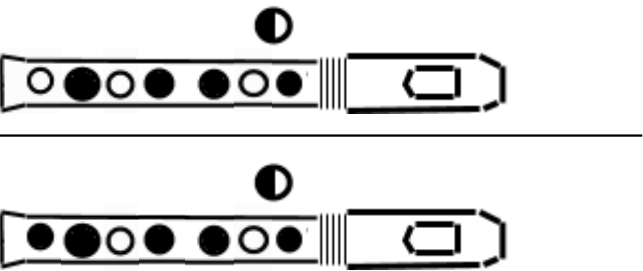
-- Ganassi Griffe -- Bass in G

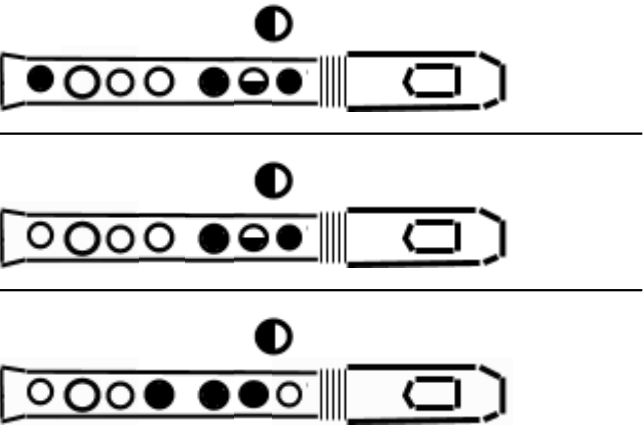
| | | |
|-------------------------------------|---|---|
| <p>Fis/Ges 2. Oktave</p> |  |  |
| <p>G 3. Oktave</p> |  |  <p style="text-align: right;">Loch 2: dreiviertel schließen</p> |
| <p>Gis/As 3. Oktave</p> |  |  |
| <p>A 3. Oktave</p> |  |  |

-- Ganassi Griffe -- Bass in G

5 (5)

| | | | |
|-------------------------------------|--|--|-------------------------------------|
| <p>Ais/B 3. Oktave</p> | | | <p>Ais/B 3. Oktave</p> |
| <p>H 3. Oktave</p> | | | <p>H 3. Oktave</p> |
| <p>C 3. Oktave</p> | | | <p>C 3. Oktave</p> |
| <p>Cis/Des 3. Oktave</p> | | | <p>Cis/Des 3. Oktave</p> |
| <p>D 3. Oktave</p> | | | <p>D 3. Oktave</p> |

>>> Der erste Griff ist der Hauptgriff, die weiteren sind Ersatz- und Nebengriffe.