











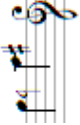

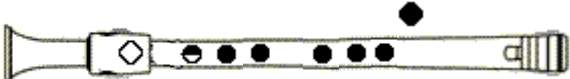
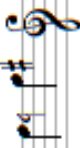



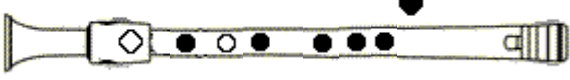
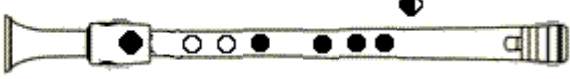
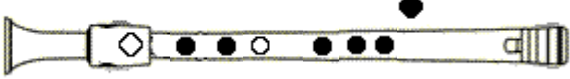
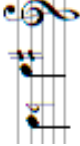
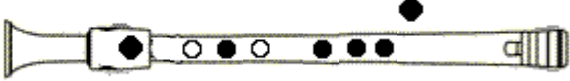
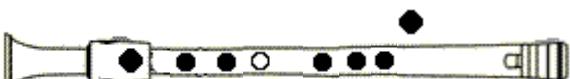

Blockis Blockflötengriffe

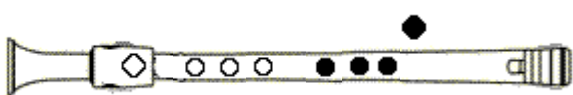
C 1. Oktave				C 1. Oktave
Cis/Des 1. Oktave				Cis/Des 1. Oktave
D 1. Oktave				D 1. Oktave
Dis/Es 1. Oktave				Dis/Es 1. Oktave
				
				
E 1. Oktave				E 1. Oktave
F 1. Oktave				F 1. Oktave
				
				
Fis/Ges 1. Oktave				Fis/Ges 1. Oktave
				
				

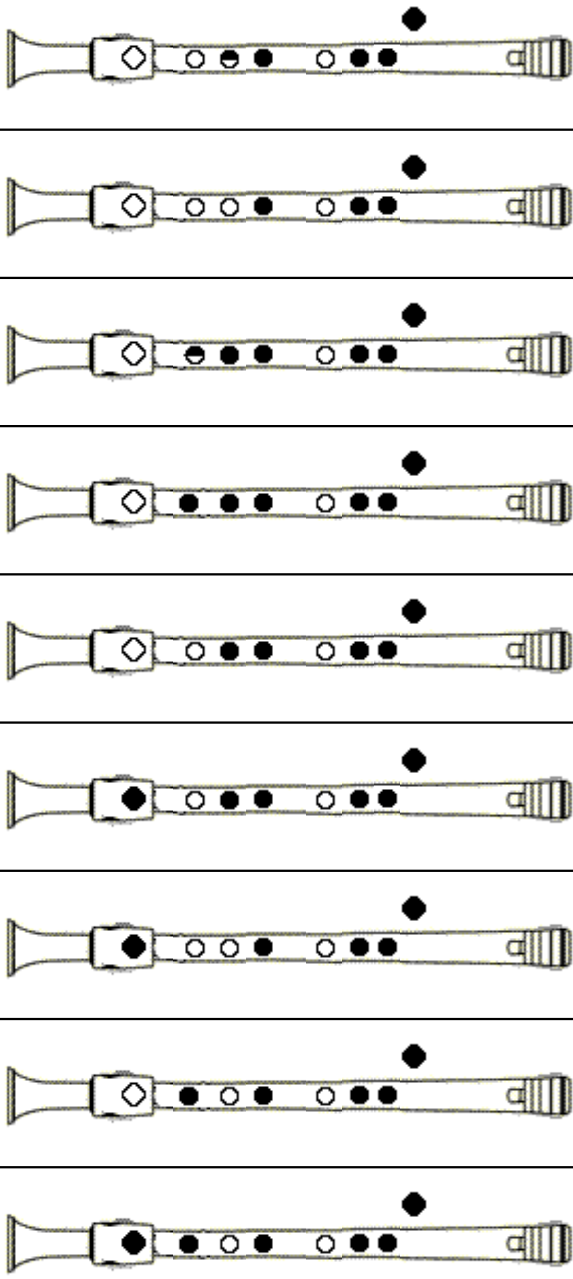
-- Renaissance Griffe -- Sopran

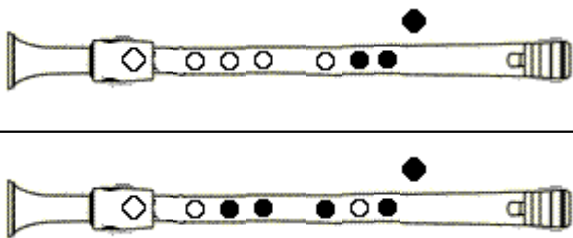
-- Renaissance Griffe -- Sopran

2 (9)

<p>G 1. Oktave</p>			<p>G 1. Oktave</p>
<p>Gis/As 1. Oktave</p>			<p>Gis/As 1. Oktave</p>
<p>A 1. Oktave</p>			<p>A 1. Oktave</p>
<p>Ais/B 1. Oktave</p>			<p>Ais/B 1. Oktave</p>

-- Renaissance Griffe -- Sopran

3 (9)









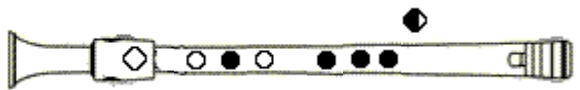

<p>H 1. Oktave</p>		
<p>C 2. Oktave</p>		
<p>Cis/Des 2. Oktave</p>		

-- Renaissance Griffe -- Sopran

5 (9)

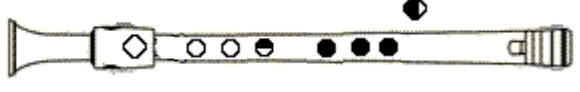
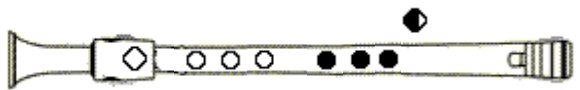
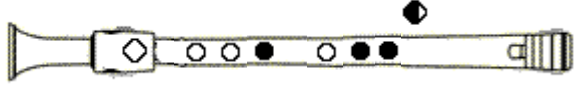
		<p>E 2. Oktave</p>
<p>E 2. Oktave</p>		<p>F 2. Oktave</p>
<p>F 2. Oktave</p>		<p>Fis/Ges 2. Oktave</p>

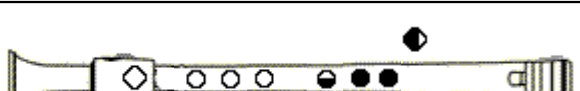
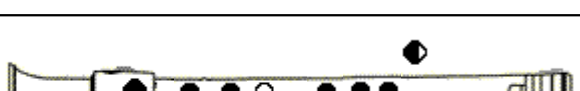
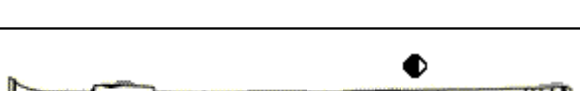
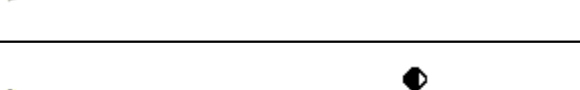
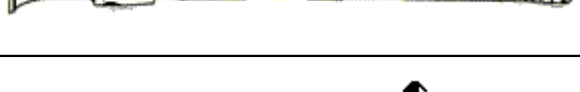
-- Renaissance Griffe -- Sopran

	<p>G 2. Oktave</p> 	<p>Gis/As 2. Oktave</p> 
		
		
<p>G 2. Oktave</p>		<p>Gis/As 2. Oktave</p>        









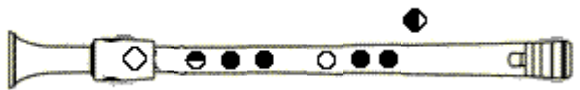
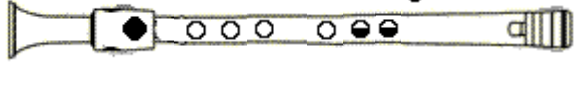
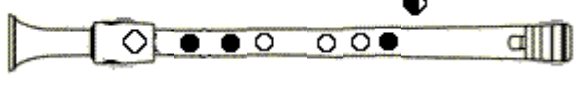
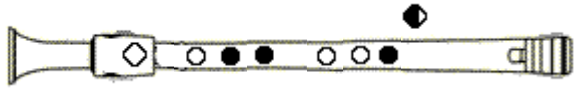

-- Renaissance Griffe -- Sopran

7 (9)

<p>A 2. Oktave</p>		
<p>Ais/B 2. Oktave</p>		<p>nur für legato</p>
<p>A 2. Oktave</p>	<p>Ais/B 2. Oktave</p>	<p>H 2. Oktave</p>

-- Renaissance Griffe -- Sopran

8 (9)

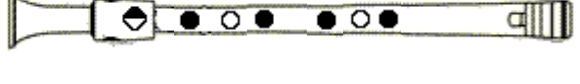
	<p>C 3. Oktave</p> 	<p>Cis/Des 3. Oktave</p> 	<p>D 3. Oktave</p> 
  	    	  	 
	<p>C 3. Oktave</p>	<p>Cis/Des 3. Oktave</p>	<p>D 3. Oktave</p>

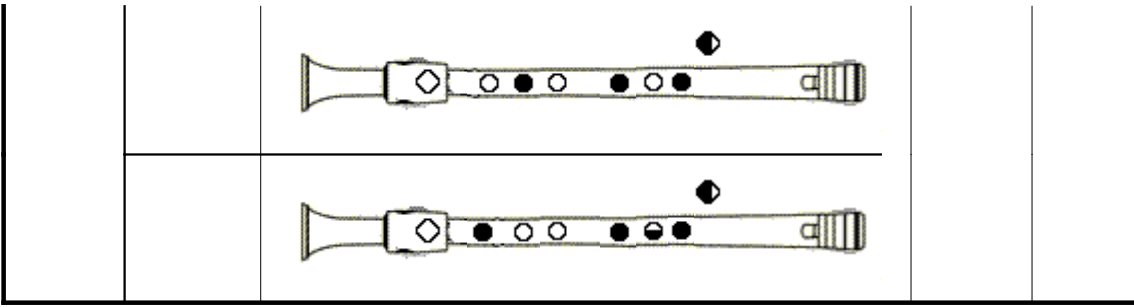

>>> Der erste Griff ist der Hauptgriff, die weiteren sind Ersatz- und Nebengriffe.

(FPDF/Arial)de-2019-05-20 [74.34/t161/]