

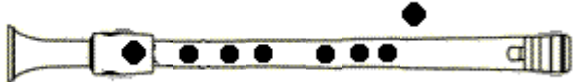













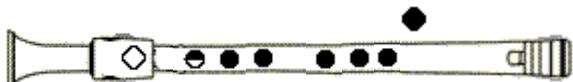







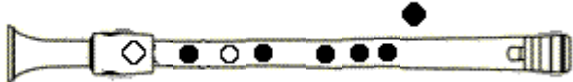

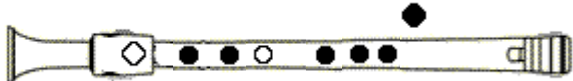

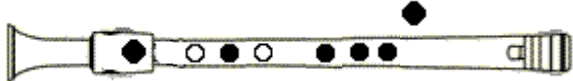
Blockis Blockflötengriffe

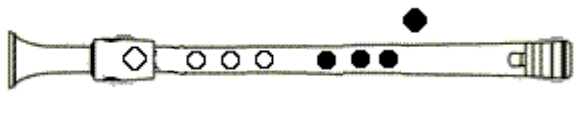
F 1. Oktave				F 1. Oktave
Fis/Ges 1. Oktave				Fis/Ges 1. Oktave
G 1. Oktave				G 1. Oktave
Gis/As 1. Oktave				Gis/As 1. Oktave
				
				
A 1. Oktave				A 1. Oktave
Ais/B 1. Oktave				Ais/B 1. Oktave
				
				
H 1. Oktave				H 1. Oktave
				
				

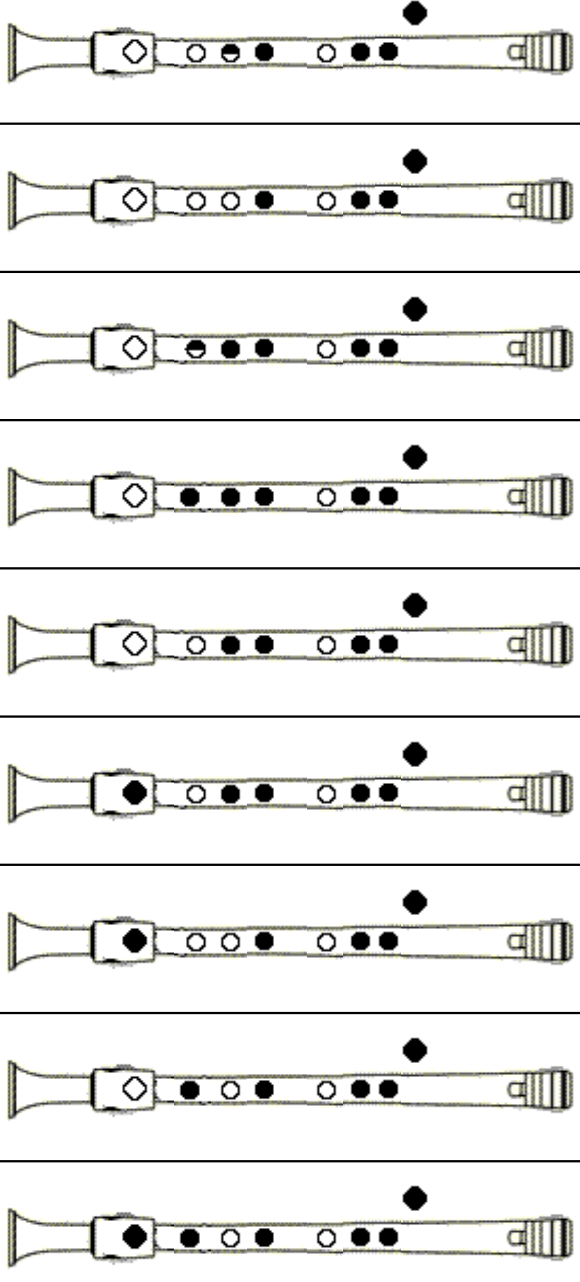
-- Renaissance Griffe -- Bass

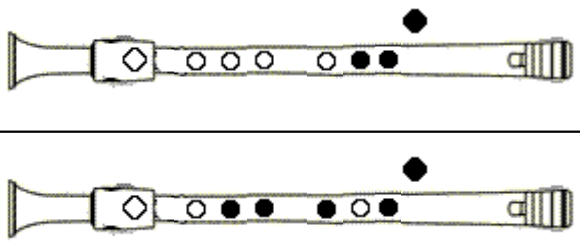
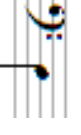
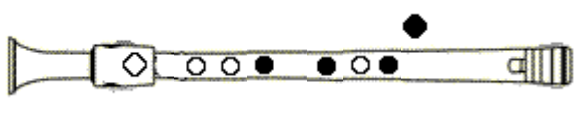
-- Renaissance Griffe -- Bass

<p>C 1. Oktave</p>			<p>C 1. Oktave</p>
<p>Cis/Des 1. Oktave</p>			<p>Cis/Des 1. Oktave</p>
<p>D 1. Oktave</p>			<p>D 1. Oktave</p>
<p>Dis/Es 1. Oktave</p>			<p>Dis/Es 1. Oktave</p>











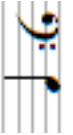

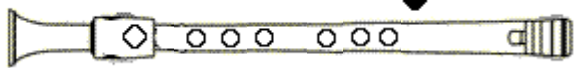
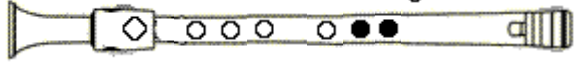

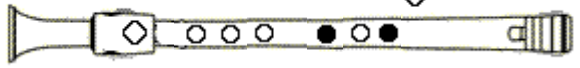

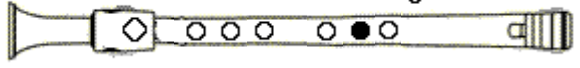
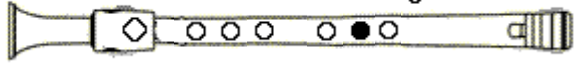
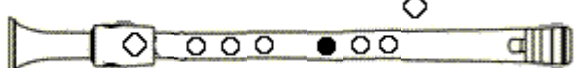
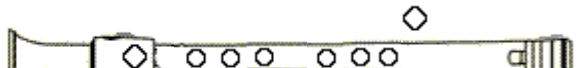
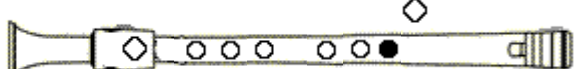
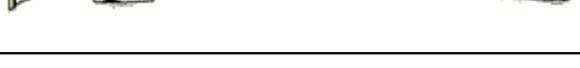

-- Renaissance Griffe -- Bass

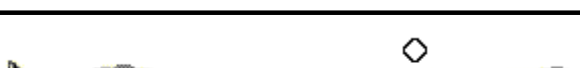
3 (9)

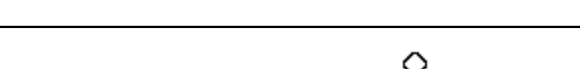
<p>E 1. Oktave</p>		
<p>F 2. Oktave</p>		
<p>Fis/Ges 2. Oktave</p>		

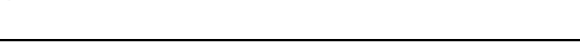
-- Renaissance Griffe -- Bass

4 (9)









	<p>G 2. Oktave</p> 	<p>Gis/As 2. Oktave</p> 
		
		
		
		
<p>G 2. Oktave</p>		<p>Gis/As 2. Oktave</p>
		
		
		
		
<p>Gis/As 2. Oktave</p>		

-- Renaissance Griffe -- Bass

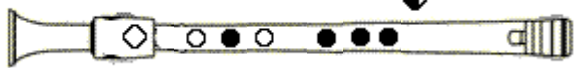
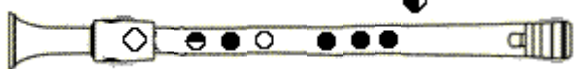
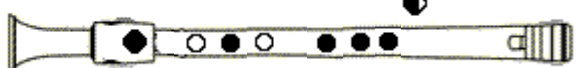
5 (9)

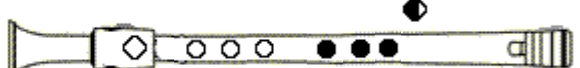
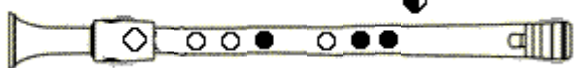
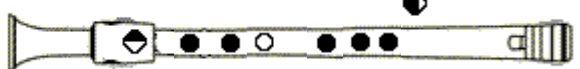
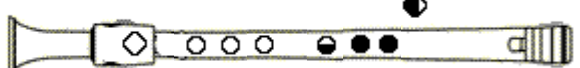
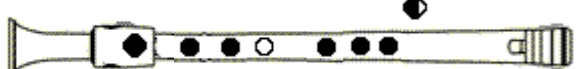

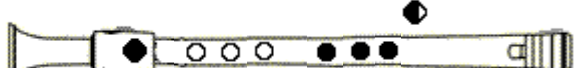

		<p>A 2. Oktave</p>
<p>A 2. Oktave</p>		<p>Ais/B 2. Oktave</p>
<p>Ais/B 2. Oktave</p>		<p>H 2. Oktave</p>

-- Renaissance Griffe -- Bass

	<p>C 2. Oktave</p> 	<p>Cis/Des 2. Oktave</p> 
    		      
	<p>C 2. Oktave</p>	<p>Cis/Des 2. Oktave</p>

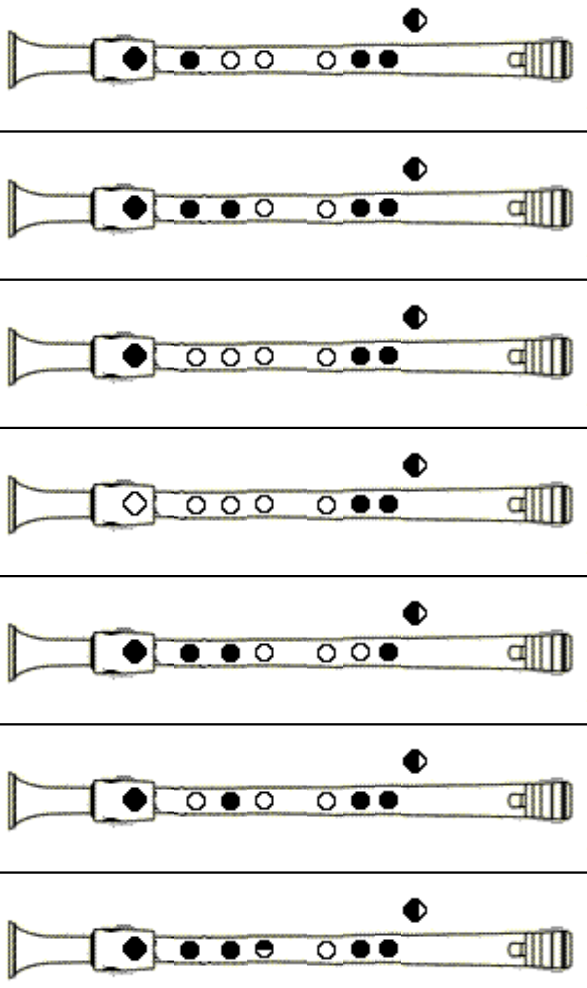

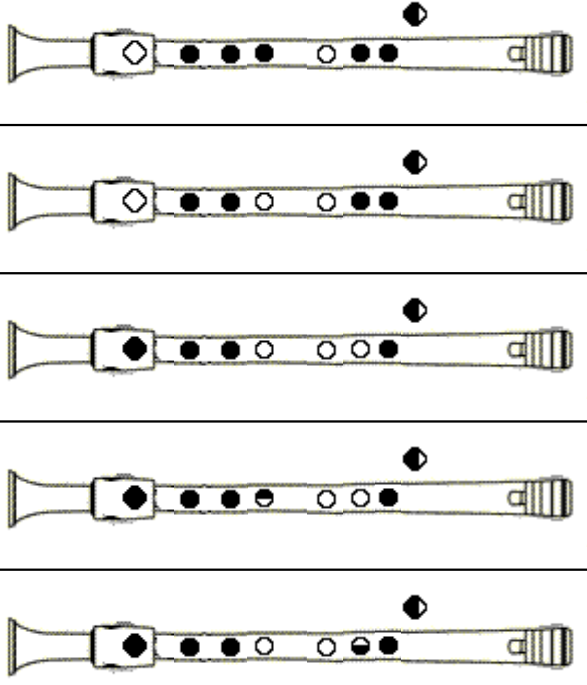

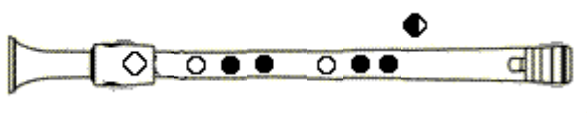

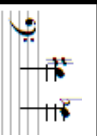

-- Renaissance Griffe -- Bass

7 (9)

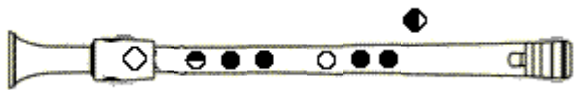
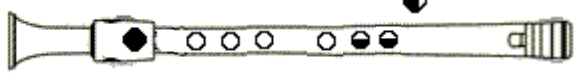
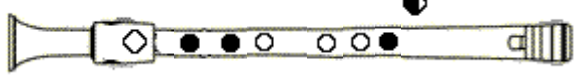
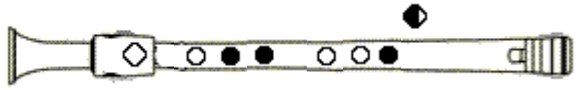
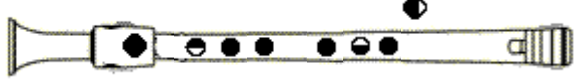
<p>D 2. Oktave</p>		
<p>Dis/Es 2. Oktave</p>		 <p>nur für legato</p>
<p>E 2. Oktave</p>		

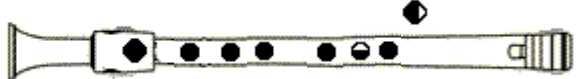
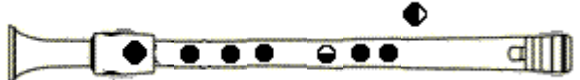
-- Renaissance Griffe -- Bass

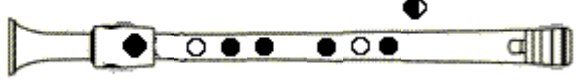
8 (9)

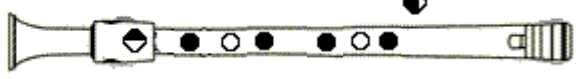
	 <p>F 3. Oktave</p>	 <p>Fis/Ges 3. Oktave</p>	 <p>G 3. Oktave</p>
  	    	  	 
	<p>F 3. Oktave</p>	<p>Fis/Ges 3. Oktave</p>	<p>G 3. Oktave</p>

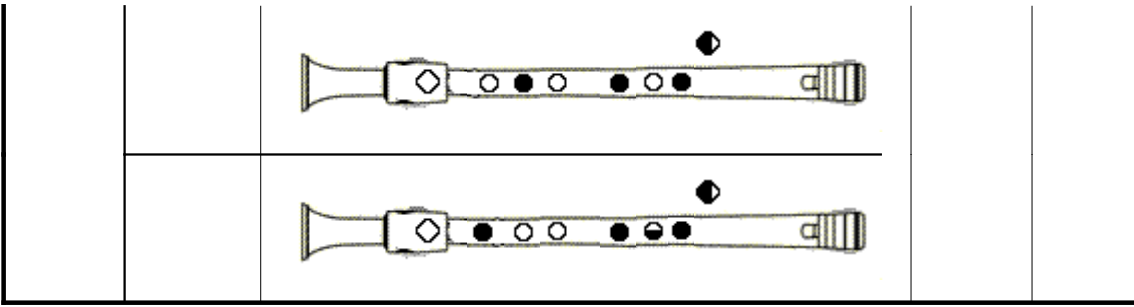

>>> Der erste Griff ist der Hauptgriff, die weiteren sind Ersatz- und Nebengriffe.

(FPDF/Arial)de-2019-05-20 [74.34/t161/]