











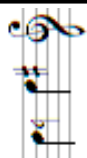



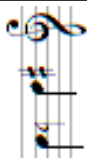







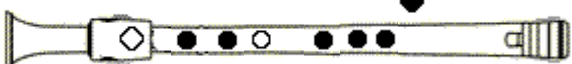

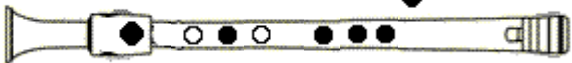
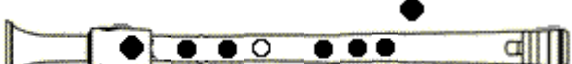
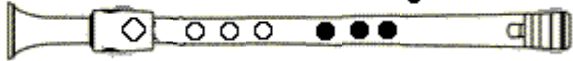





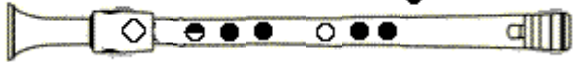

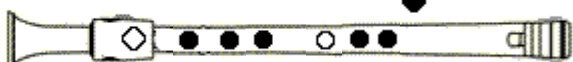
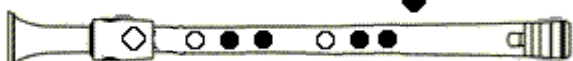



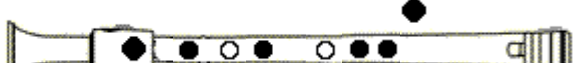

# Blockis recorder fingerings

<b>F</b> 1st octave				<b>F</b> 1st octave
<b>F#/Gb</b> 1st octave				<b>F#/Gb</b> 1st octave
<b>G</b> 1st octave				<b>G</b> 1st octave
<b>G#/Ab</b> 1st octave				<b>G#/Ab</b> 1st octave
				
				
<b>A</b> 1st octave				<b>A</b> 1st octave
<b>A#/Bb</b> 1st octave				<b>A#/Bb</b> 1st octave
				
				
<b>B</b> 1st octave				<b>B</b> 1st octave
				
				

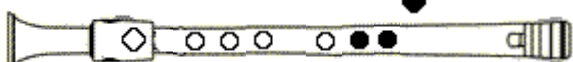
-- Renaissance fingerings -- Alto

-- Renaissance fingerings -- Alto

C 1st octave			C 1st octave	
C#/Db 1st octave			C#/Db 1st octave	
				
				
				
				
				
				
				
				
D 1st octave			D 1st octave	
D#/Eb 1st octave			D#/Eb 1st octave	









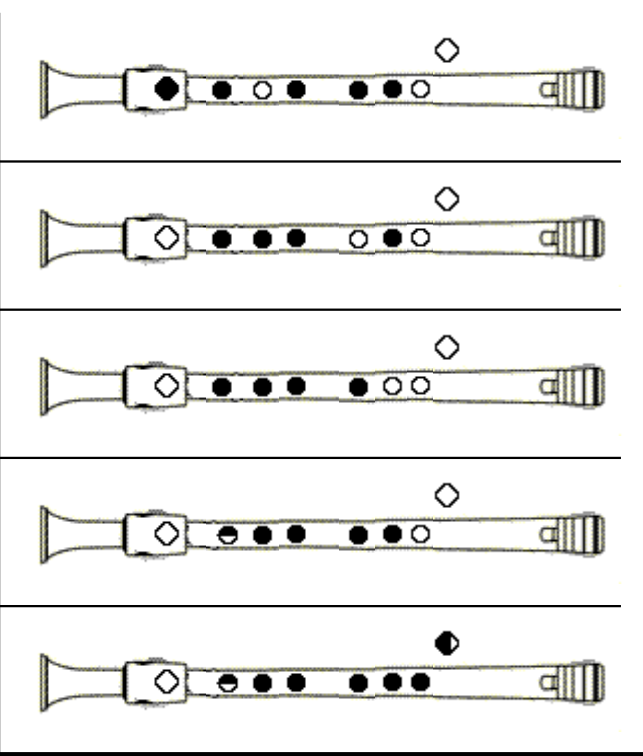

-- Renaissance fingerings -- Alto

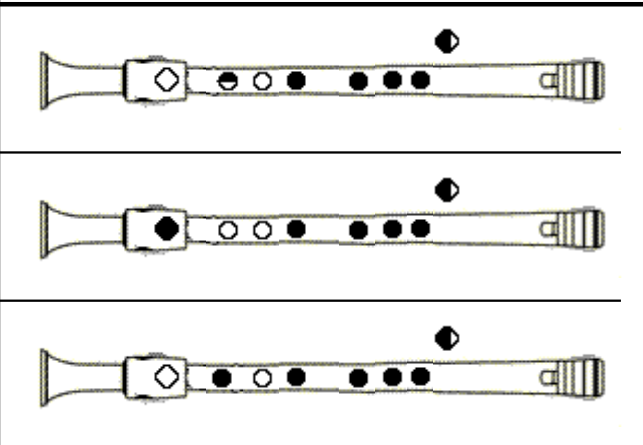
<p>E 1st octave</p>		
<p>F 2nd octave</p>		
<p>F#/Gb 2nd octave</p>		

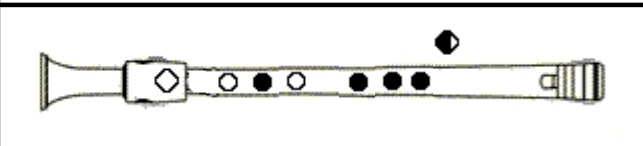

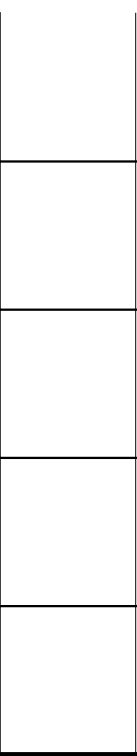
-- Renaissance fingerings -- Alto

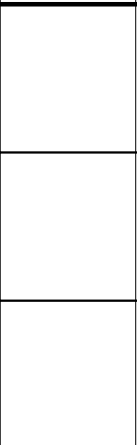
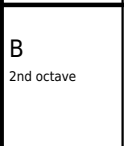
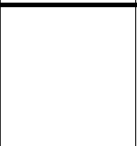
<p>G 2nd octave</p>		
<p>G#/Ab 2nd octave</p>		



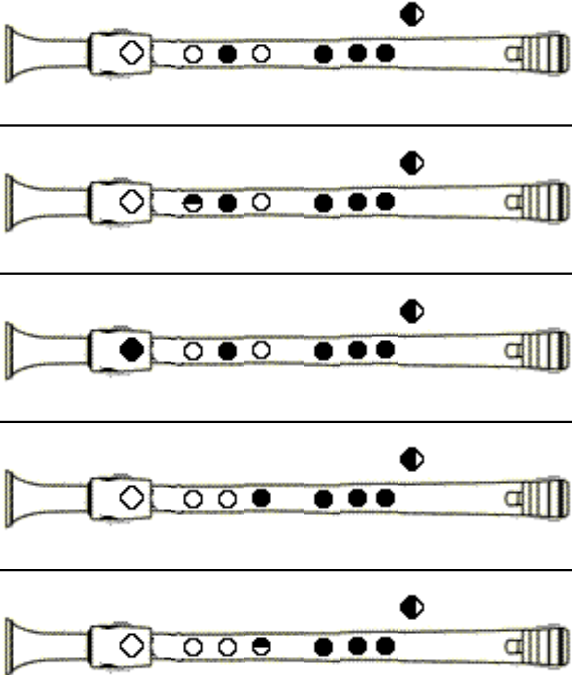

-- Renaissance fingerings -- Alto

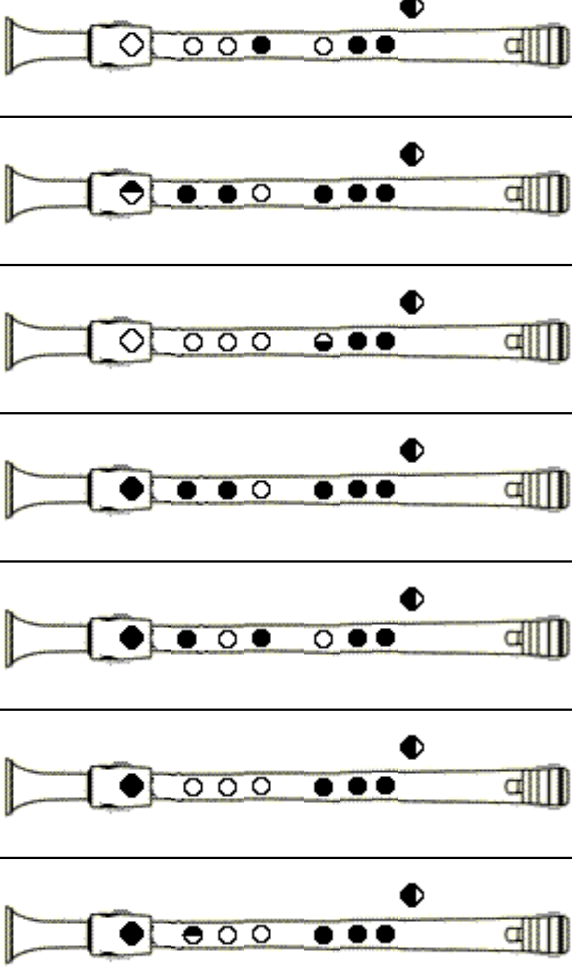
		<p>A 2nd octave</p> 
<p>A#/ Bb 2nd octave</p>		<p>A#/ Bb 2nd octave</p> 
<p>B 2nd octave</p>		<p>B 2nd octave</p> 
<p>A 2nd octave</p>		<p>A 2nd octave</p> 
<p>A#/ Bb 2nd octave</p>		<p>A#/ Bb 2nd octave</p> 
<p>B 2nd octave</p>		<p>B 2nd octave</p> 

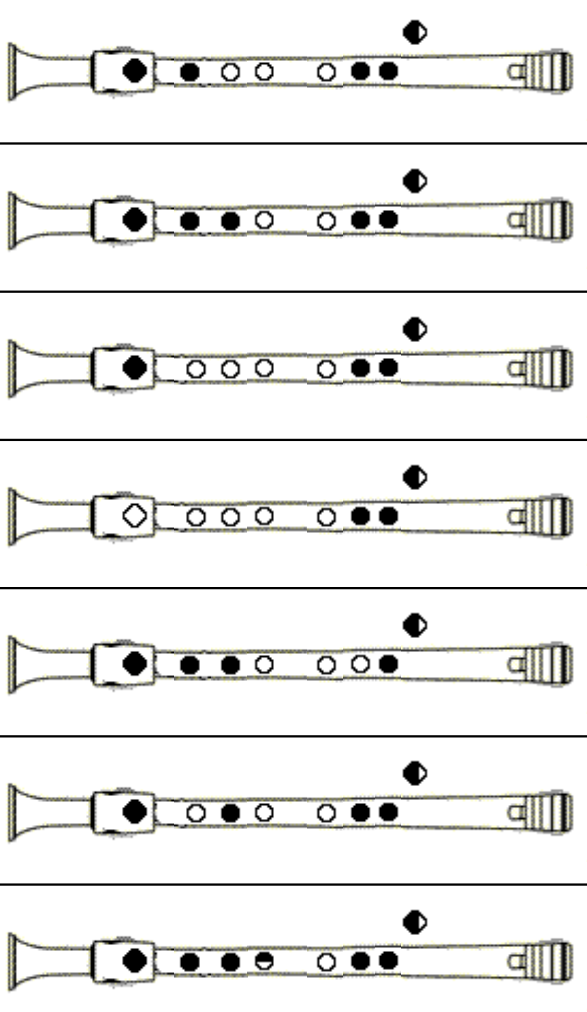

-- Renaissance fingerings -- Alto

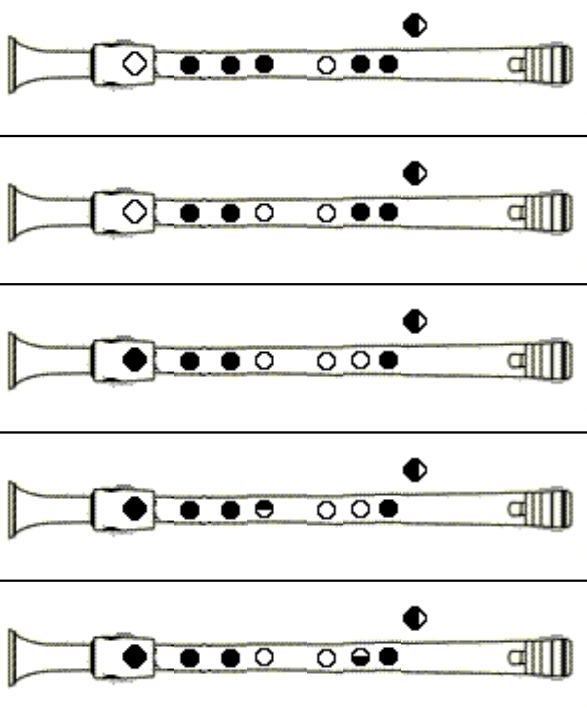
	<p>C 2nd octave</p> 	
<p>C#/Db 2nd octave</p> 		

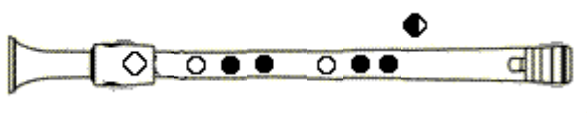
-- Renaissance fingerings -- Alto

<p>D 2nd octave</p>		
<p>D#/Eb 2nd octave</p>		
<p>E 2nd octave</p>		

# -- Renaissance fingerings -- Alto

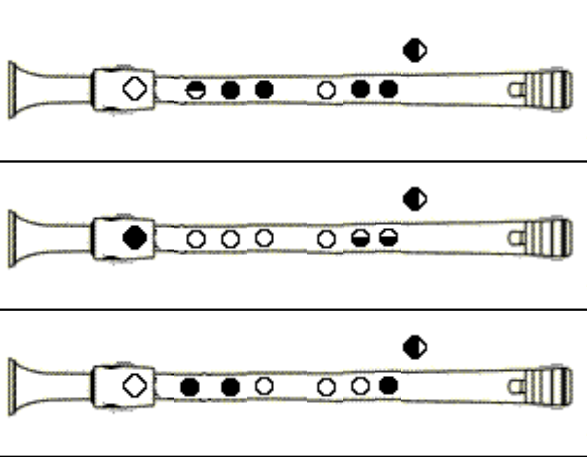
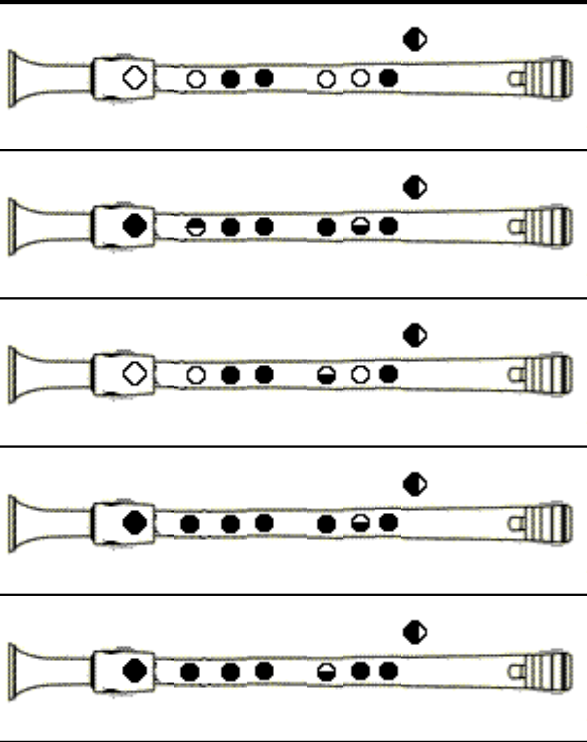
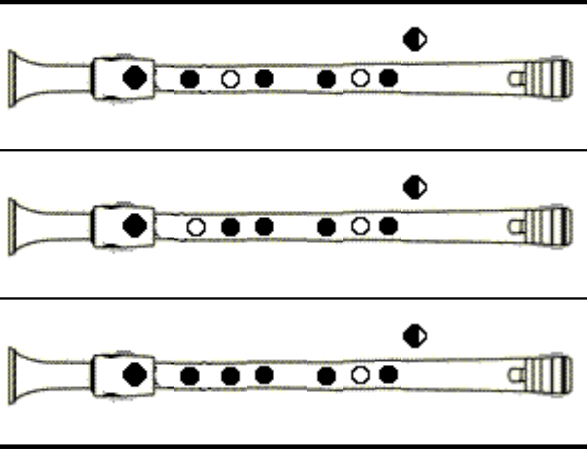
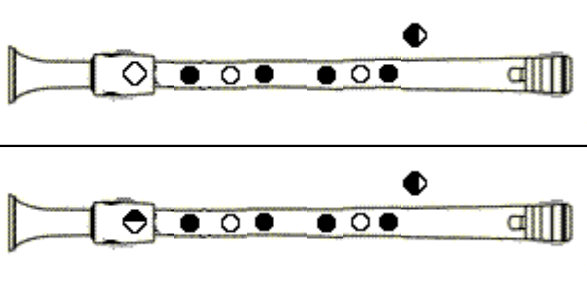
	 <p>F 3rd octave</p>	 <p>F#/Gb 3rd octave</p>	 <p>G 3rd octave</p>
			



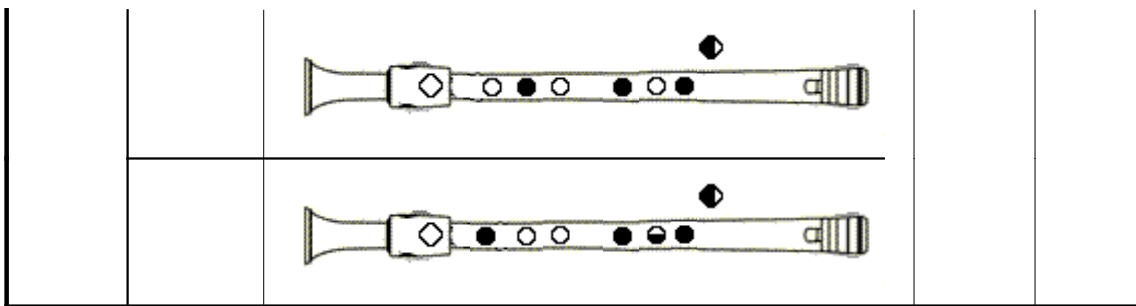

>>> The first fingering is the recommended fingering, the others are alternative fingerings.

(FPDF/DejaVu)en-2021-03-02 [74.36/t161/]