

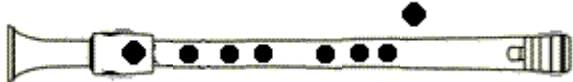













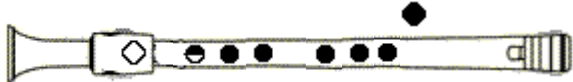

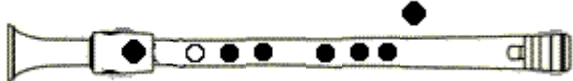
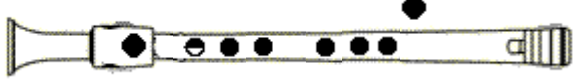



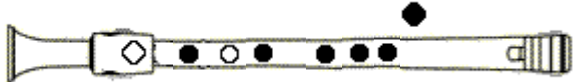

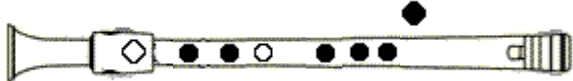

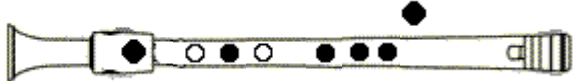
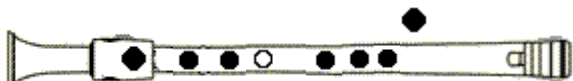
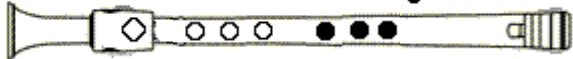

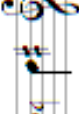



Blockis recorder fingerings

-- Renaissance fingerings -- Tenor

C 1st octave				C 1st octave
C#/Db 1st octave				C#/Db 1st octave
D 1st octave				D 1st octave
D#/Eb 1st octave				D#/Eb 1st octave
				
				
E 1st octave				E 1st octave
F 1st octave				F 1st octave
				
				
F#/Gb 1st octave				F#/Gb 1st octave
				
				







-- Renaissance fingerings -- Tenor

<p>G 1st octave</p>				<p>G 1st octave</p>
<p>G#/Ab 1st octave</p>				<p>G#/Ab 1st octave</p>
				
				
				
				
				
				
				
<p>A 1st octave</p>				<p>A 1st octave</p>
<p>A#/Bb 1st octave</p>				<p>A#/Bb 1st octave</p>

-- Renaissance fingerings -- Tenor

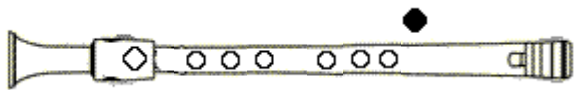
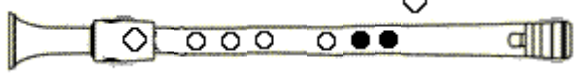
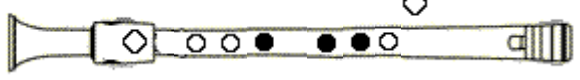
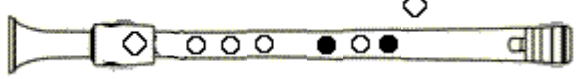
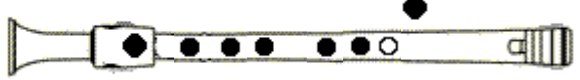
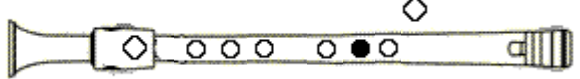
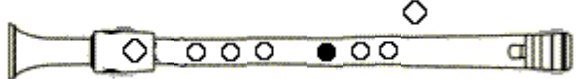
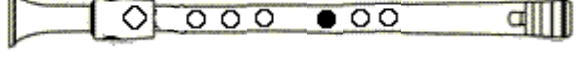
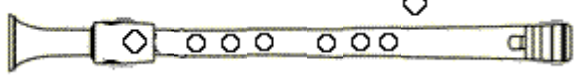
<p>B 1st octave</p>		
<p>C 2nd octave</p>		
<p>C#/Db 2nd octave</p>		

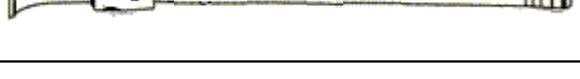







-- Renaissance fingerings -- Tenor

	<p>D 2nd octave</p> 	<p>D#/Eb 2nd octave</p> 
		
		
		
		
		
	<p>D 2nd octave</p>	<p>D#/Eb 2nd octave</p>

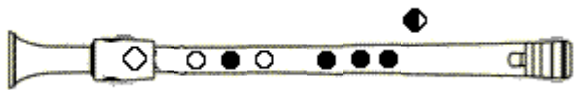

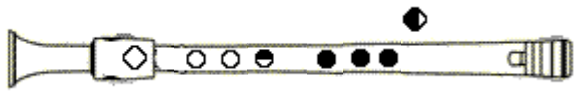
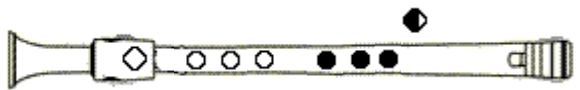

-- Renaissance fingerings -- Tenor

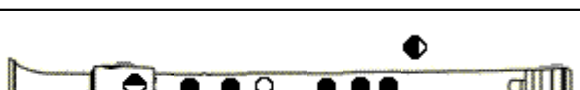
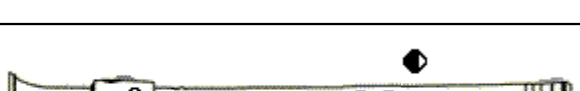
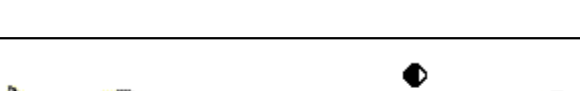
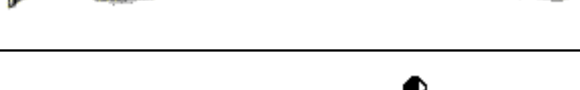
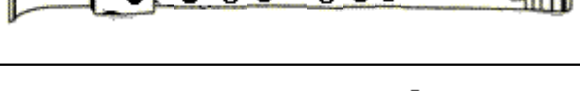
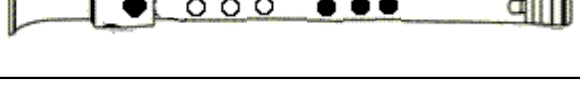
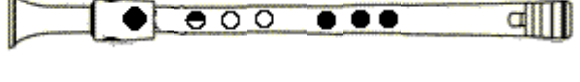
<p>E 2nd octave</p>		
<p>F 2nd octave</p>		
<p>F#/Gb 2nd octave</p>		

-- Renaissance fingerings -- Tenor

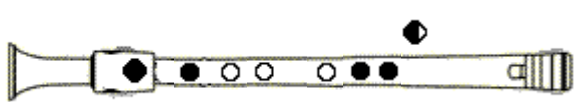
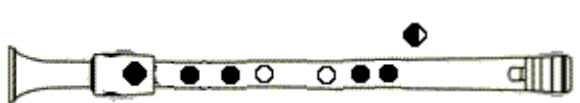
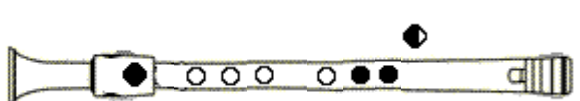
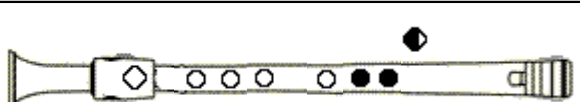
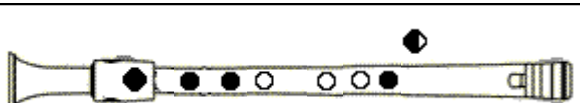
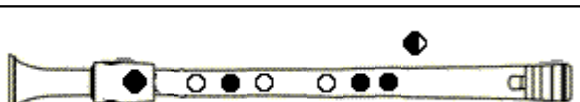
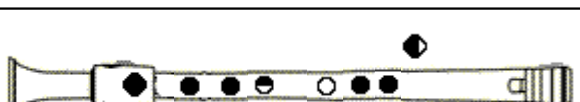

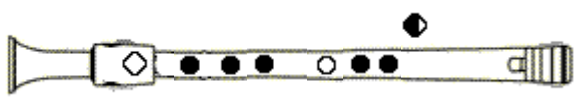
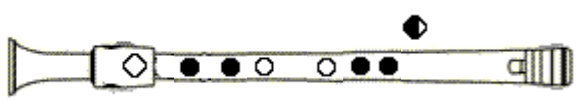
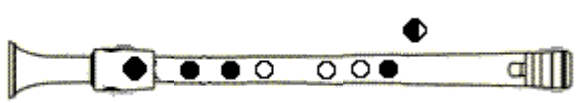
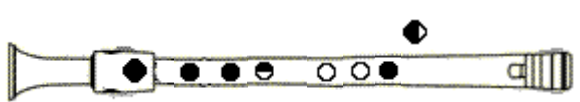
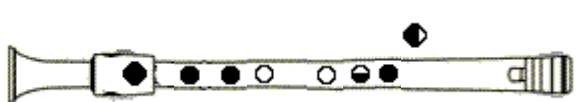
	<p>G 2nd octave</p> 	<p>G#/Ab 2nd octave</p> 
		
		
<p>G 2nd octave</p>		<p>G#/Ab 2nd octave</p>       

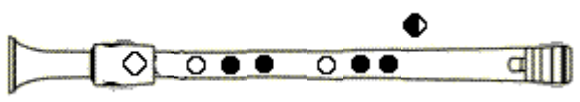
-- Renaissance fingerings -- Tenor

<p>A 2nd octave</p>	       
<p>A#/Bb 2nd octave</p>	     
<p>B 2nd octave</p>	 

only for legato

-- Renaissance fingerings -- Tenor

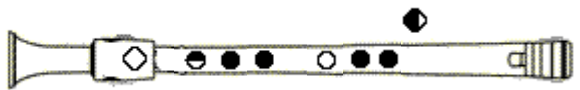
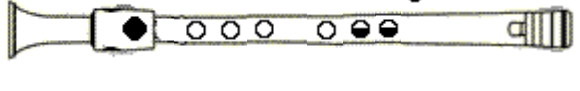
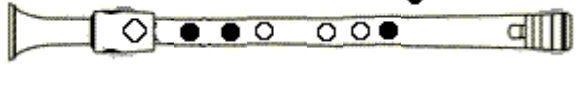
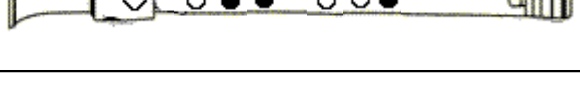
	 <p>C 3rd octave</p>	 <p>C#/Db 3rd octave</p>	 <p>D 3rd octave</p>
			
	<p>C 3rd octave</p>	<p>C#/Db 3rd octave</p>	<p>D 3rd octave</p>

-- Renaissance fingerings -- Tenor

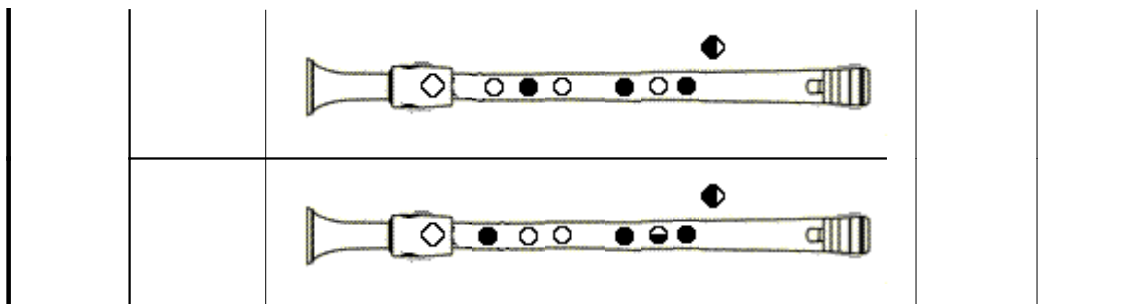

>>> The first fingering is the recommended fingering, the others are alternative fingerings.

(FPDF/DejaVu)en-2024-12-12 [74.36/t161/]