

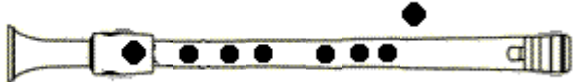

























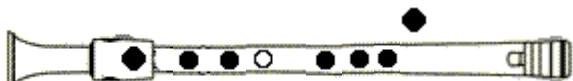
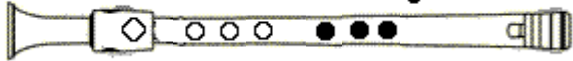

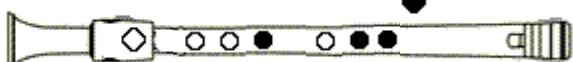



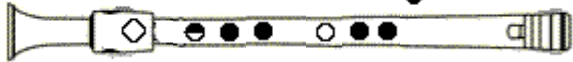

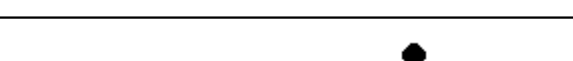

Blockis recorder fingerings

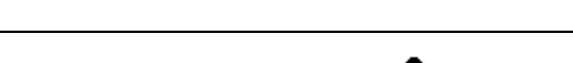
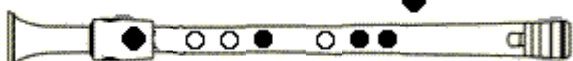
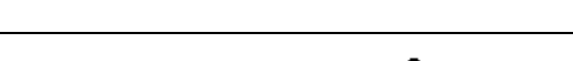
-- Renaissance fingerings -- Bass

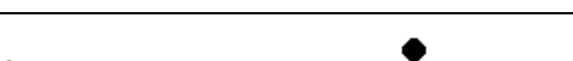
F 1st octave				F 1st octave
F#/Gb 1st octave				F#/Gb 1st octave
G 1st octave				G 1st octave
G#/Ab 1st octave				G#/Ab 1st octave
				
				
A 1st octave				A 1st octave
A#/Bb 1st octave				A#/Bb 1st octave
				
				
B 1st octave				B 1st octave
				
				

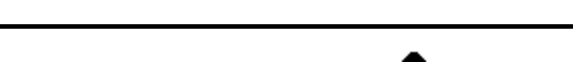
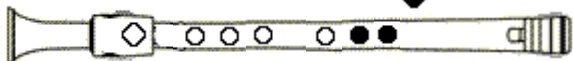

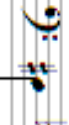



-- Renaissance fingerings -- Bass

<p>C 1st octave</p>			
<p>C#/Db 1st octave</p>			
			
			
			
			
			
			
			
			
<p>D 1st octave</p>			
<p>D#/Eb 1st octave</p>			

-- Renaissance fingerings -- Bass

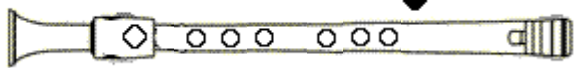
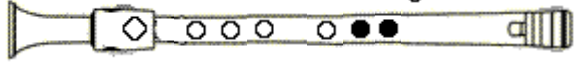
<p>E 1st octave</p>		<p>E 1st octave</p>
<p>F 2nd octave</p>		<p>F 2nd octave</p>
<p>F#/Gb 2nd octave</p>		<p>F#/Gb 2nd octave</p>

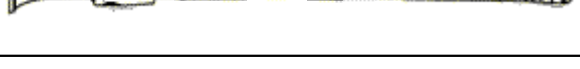
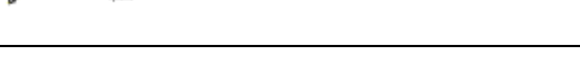
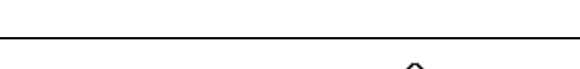
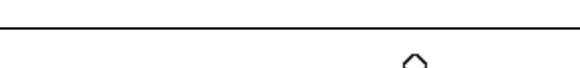
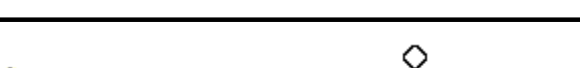
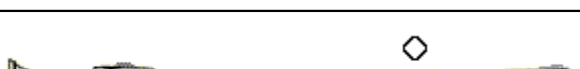

-- Renaissance fingerings -- Bass

	<p>G 2nd octave</p> 	<p>G#/Ab 2nd octave</p> 
		
		
		
		
	<p>G 2nd octave</p>	<p>G#/Ab 2nd octave</p>



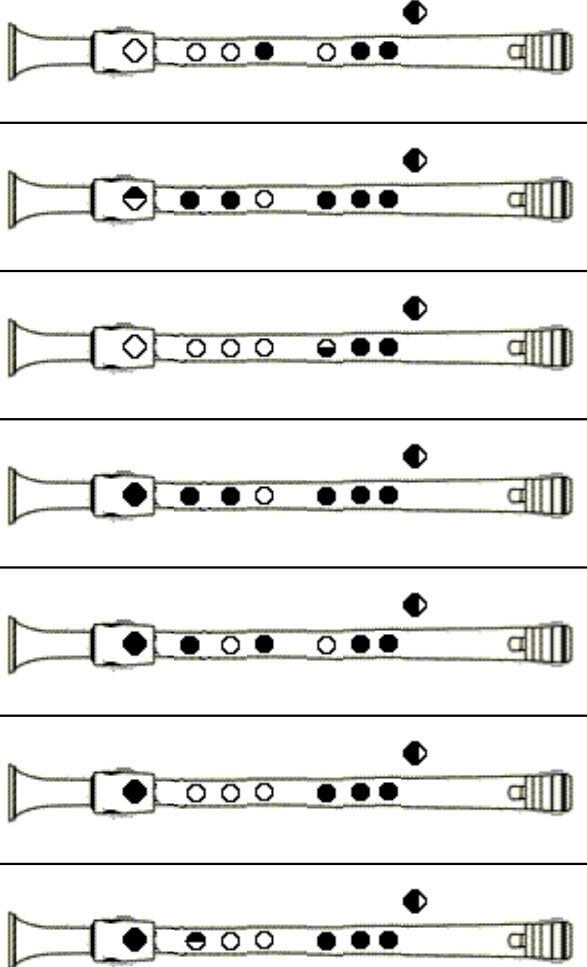

-- Renaissance fingerings -- Bass

		<p>A 2nd octave</p>
<p>A#/Bb 2nd octave</p>		
<p>B 2nd octave</p>		

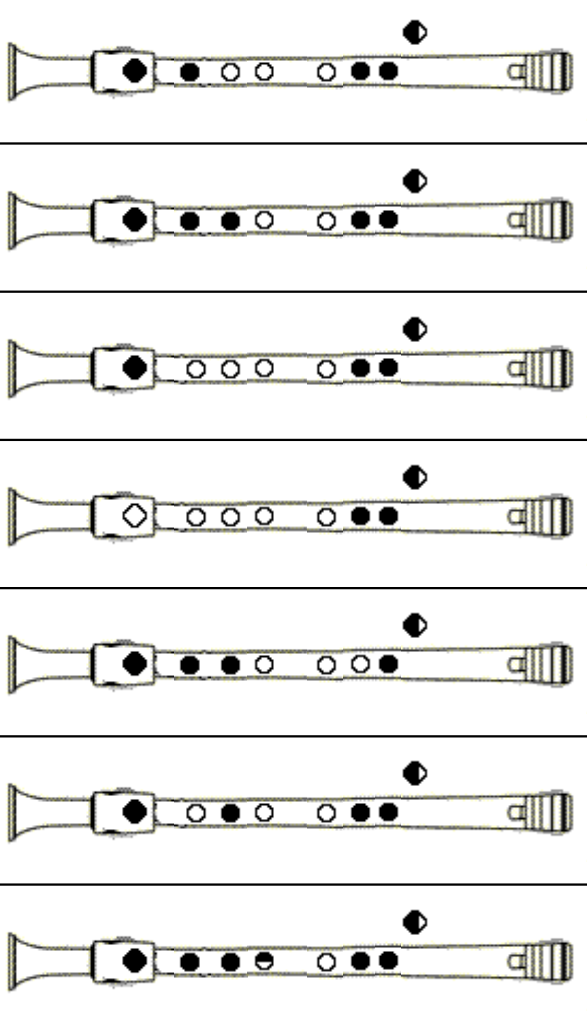

-- Renaissance fingerings -- Bass

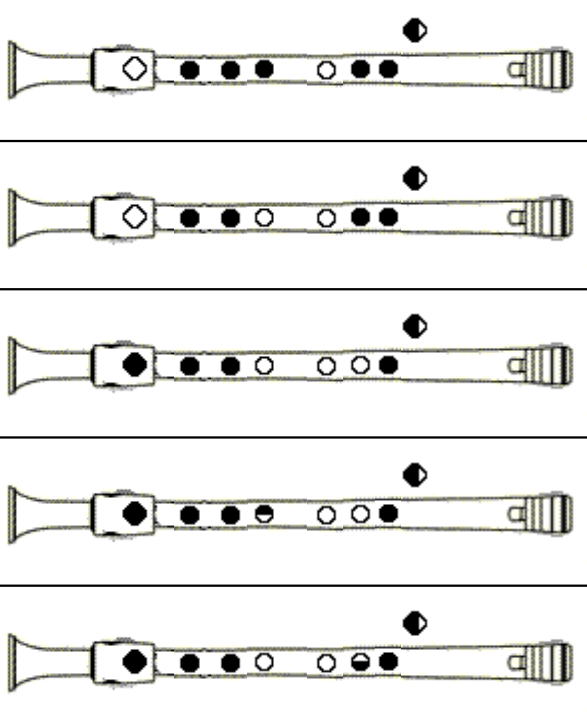
	<p>C 2nd octave</p> 	
<p>C#/Db 2nd octave</p> 		

-- Renaissance fingerings -- Bass

<p>D 2nd octave</p>		
<p>D#/Eb 2nd octave</p>		 <p style="text-align: center;">only for legato</p>
<p>E 2nd octave</p>		

-- Renaissance fingerings -- Bass

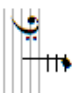
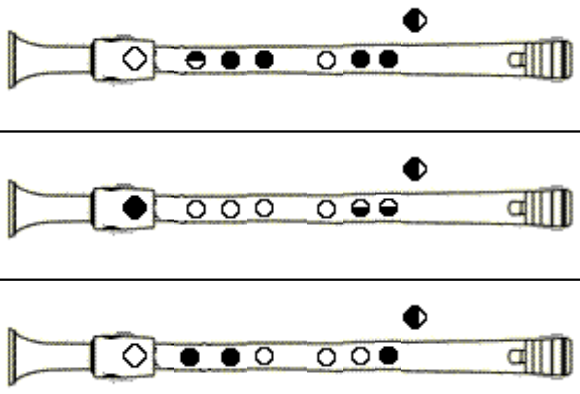
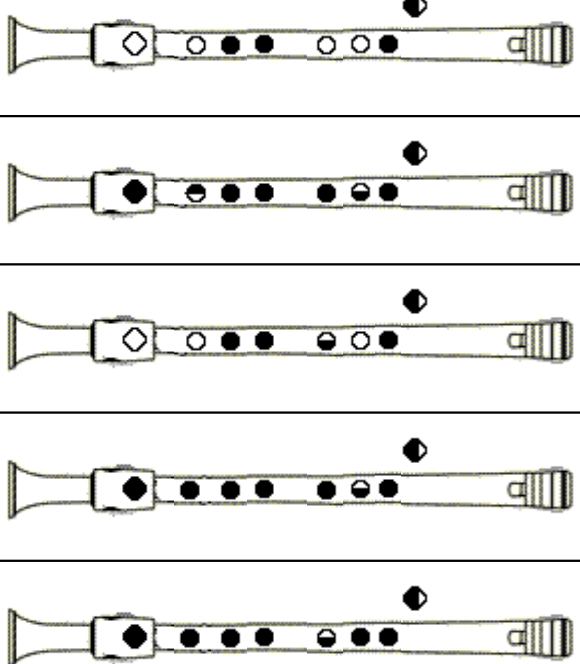
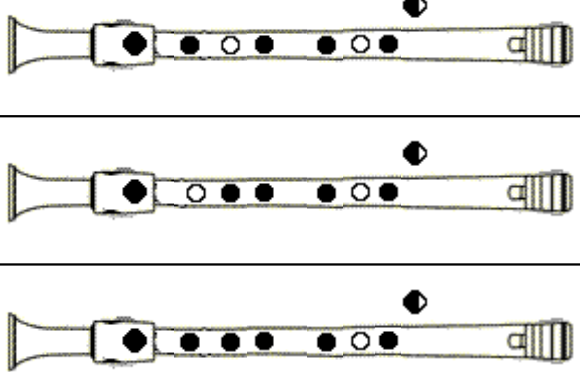
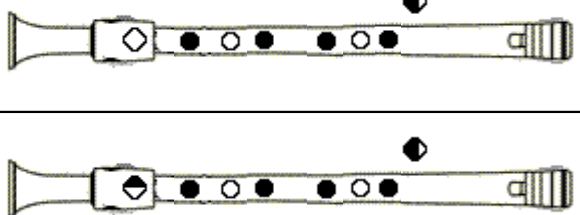
	 <p>F 3rd octave</p>	 <p>F#/Gb 3rd octave</p>	 <p>G 3rd octave</p>
			

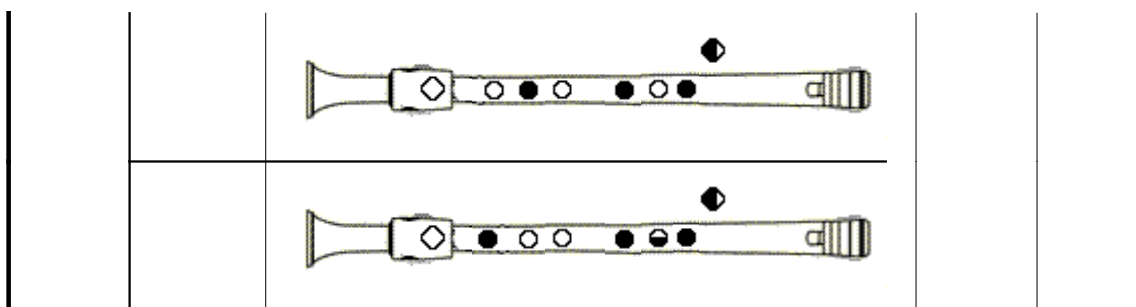

>>> The first fingering is the recommended fingering, the others are alternative fingerings.

(FPDF/DejaVu)en-2025-01-25 [74.36/t161/]